



OIL PRESSURE SWITCHES

WHAT'S IN YOUR BOX?

StandardWhatsInYourBox.com

Designed, manufactured and tested at our vertically-integrated facility for unmatched quality.

Standard® and Intermotor® oil pressure switches provide expanded coverage for import and domestic applications. Designed and manufactured to exacting specifications, oil pressure switches undergo rigorous testing to ensure consistent performance and a long service life.

What's inside the Standard® box... advanced engineering, extensive testing and over 100 years of experience. What's in your box?



Standard® PS-317 Chrysler/Dodge (2017-99)



Standard® PS-427 Ford (2018-98)

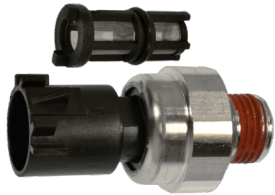

Standard® PS-508 Chevy/GMC (2019-09)
Engine Oil Pressure Filter included



Intermotor® PS-423 Mazda (2015-03)

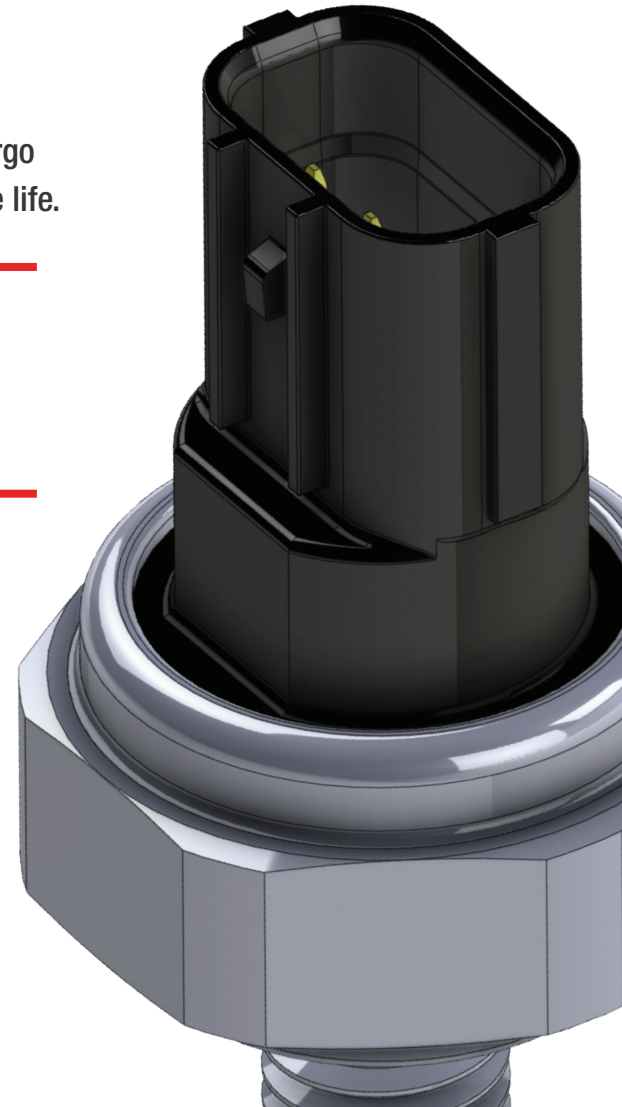

**500+
SKUs**

Standard® and Intermotor® offer more than 500 oil pressure switches for import and domestic applications



Oil pressure switches are manufactured in IATF 16949-certified facilities in North America

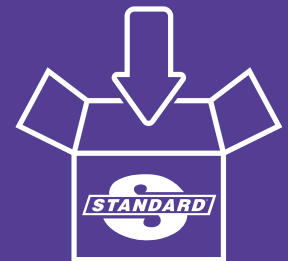

Standard® includes the engine oil pressure filter with select GM oil pressure switches where needed

Standard® and Intermotor® Oil Pressure Switches include features that make your job a little easier.

High-temp, ceramic pressure sensors provide exceptional cycle durability and resistance to rupture and oil leakage

**Standard® PS309
GM (2013-97)**

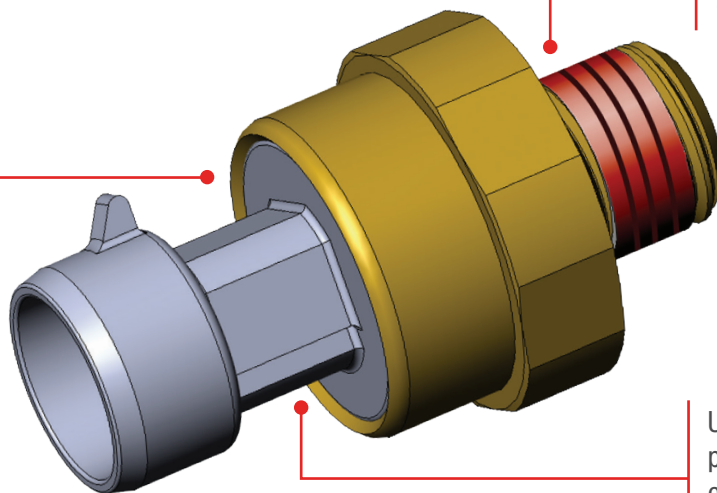

Includes pre-applied thread sealant for easy install right out of box

Undergoes computer-controlled pressure calibration testing to ensure accurate reading of actual oil pressure in vehicle's engine

What's behind our Oil Pressure Switch is as important as what's inside.

Standard® and Intermotor® oil pressure switches are manufactured in our IATF 16949 quality-certified facility in Independence, Kansas. This plant is also ISO 14001 (environmental) certified and recycles fluids, metals and all other reusable materials.

Our facility is vertically-integrated, so all switches and sensors are designed, engineered, manufactured, and tested at the same location. This means you can always count on Standard® and Intermotor® oil pressure switches to deliver precise, repeatable performance.

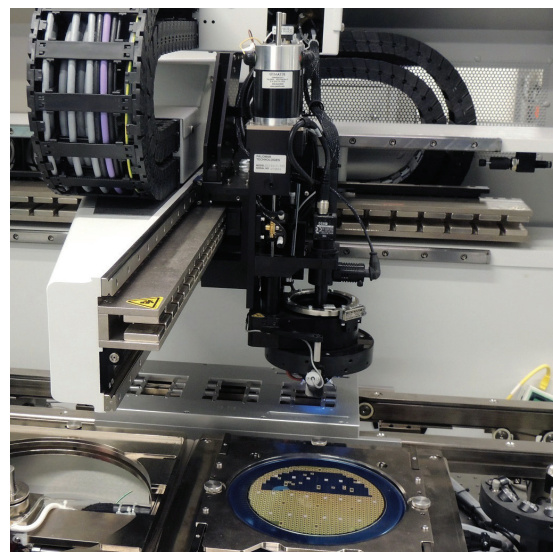

For more than 100 years, when the OE failed, technicians trusted Standard®, Blue Streak® and Intermotor® to deliver a part that's equal to or better than the original it's replacing.



STANDARDBRAND.COM



STANDARDBLUESTREAK.COM



INTERMOTORIMPORT.COM



SMPCORP.COM



ST11522