

GASOLINE DIRECT
INJECTION PROGRAM

Highlights

1

Standard® offers a full line of GDI components, everything needed for a complete GDI repair

2

Standard® GDI Injectors are always new, never remanufactured

3

Our Gasoline Direct Injectors are precision engineered and rigorously tested to ensure optimal performance



What's in your box?™

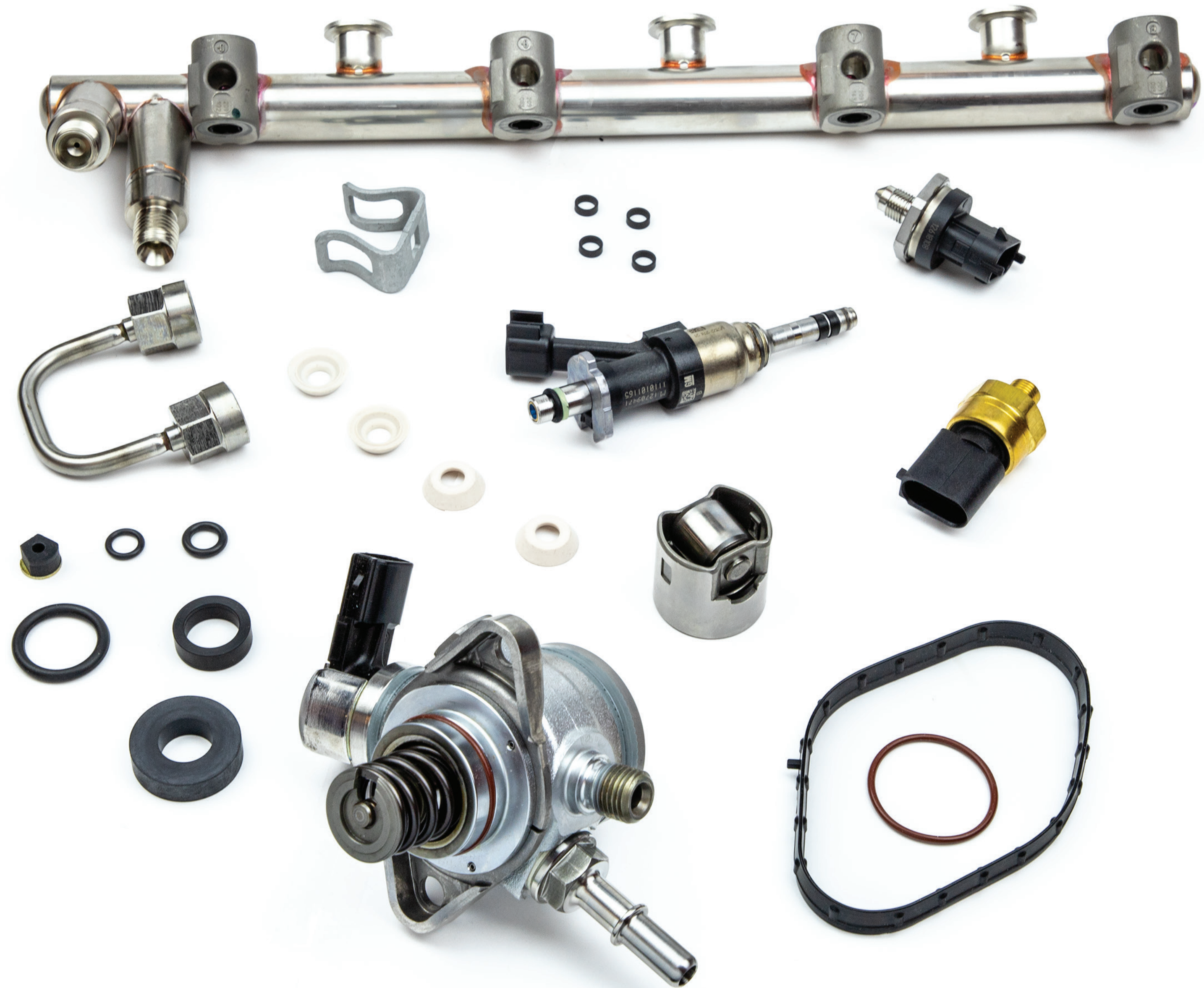

When OE Fails . . . Trust Standard®

StandardGDI.com

Growing Market

To help improve fuel economy, vehicle manufacturers have quickly adopted Gasoline Direct Injection (GDI) technology.

GDI is now the fastest growing fuel segment with more than half the U.S. fleet equipped with GDI engines.

In fact, the use of GDI engines has grown by over 600% since 2010!

New Vehicles Equipped with GDI

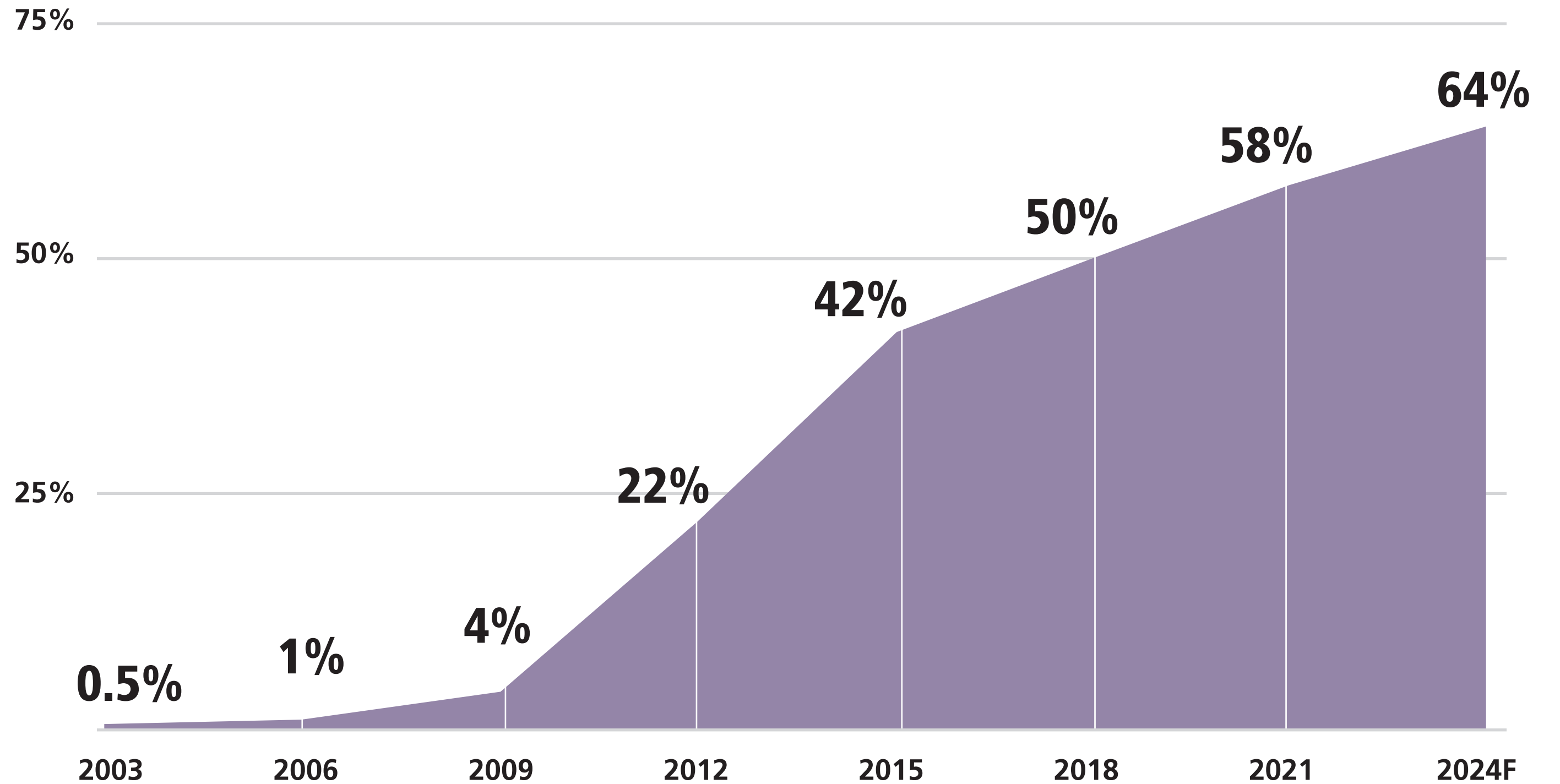

Source: SMP Internal Data

Service Opportunities:

In the next 5 years, 42 million more vehicles with GDI will enter the Aftermarket "Sweet Spot" (6-12 years old) during which their injectors and related parts may need to be serviced or replaced.

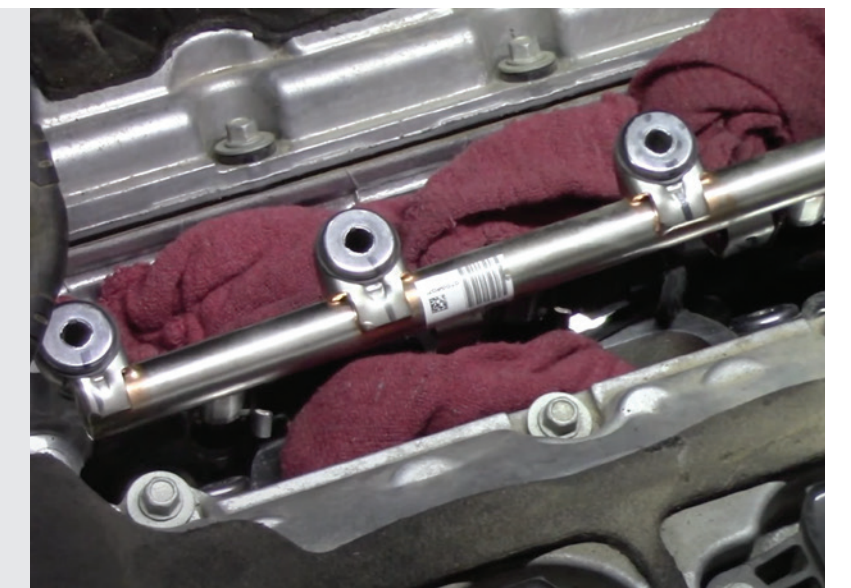

Sales Opportunities

GDI systems provide many opportunities for repair. In 2020, Honda updated a TSB, alerting techs that the original GDI injectors installed in late-model Odysseys, Pilots and Ridgelines are throwing numerous DTC codes.

PROBLEM

Debris from manufacturing clogs the original GDI injectors



Service Bulletin

18-025

November 24, 2020

Version 5

MIL Comes On with DTC P0300-P0306 or P219A/B

Supersedes 18-025, dated May 29, 2019, to revised the information highlighted in yellow.

AFFECTED VEHICLES

Year	Model	Trim Level	VIN Range
2018	Odyssey	ALL	ALL
2019		ALL	5FNRL6...KB000001 thru 5FNRL6...KB026674
2017-18	Pilot	ALL	ALL
2019		2WD ALL	5FNYF5...KB000001 thru 5FNYF5...KB001450
		4WD ALL	5FNYF6...KB000001 thru 5FNYF6...KB006305
2017-18	Ridgeline	ALL	ALL
2019		2WD ALL	5FPYK2...KB000001 thru 5FPYK2...KB002884
		4WD ALL	5FPYK3...KB000001 thru 5FPYK3...KB012495

SYMPTOM

The MIL comes on with DTC P0300 (random misfire detected), and/or P0301-P0306 (cylinder misfire detected), or P219A/B (air-fuel ratio variation of cylinder [bank 1, rear bank/bank 2, front bank]).

POSSIBLE CAUSE

Debris from the high pressure pump or the fuel injector machining process can cause internal wear or clogging inside the injector.

CORRECTIVE ACTION

Replace the fuel injectors.



STANDARD® SOLUTION

New GDI Fuel Injector

Standard's FJ1372 premium New GDI Fuel Injectors include the retaining clip to keep the Injectors in position while protecting against vibration



Gasoline Direct Injection

StandardGDI.com

Impact on Engine Systems



Fuel deposits are a common problem in GDI Engines — Left unchecked, they can foul injectors and actually alter engine timing, causing drivability problems



Under-maintained GDI systems can result in reduced fuel economy and performance and may eventually lead to a costly valve cleaning



GDI engines operate at higher temperatures which can cause the oil to break down — It's important to strictly adhere to suggested oil change intervals on GDI engines

What's New

BLUE STREAK® DIRECT INJECTION HIGH-PRESSURE FUEL PUMP KIT

Our all-in-one High-Pressure Fuel Pump Kits include all components necessary to do the job right the first time.

More GDI Fuel Pump Kits are in development and will be released soon.

GDP204K includes the following:

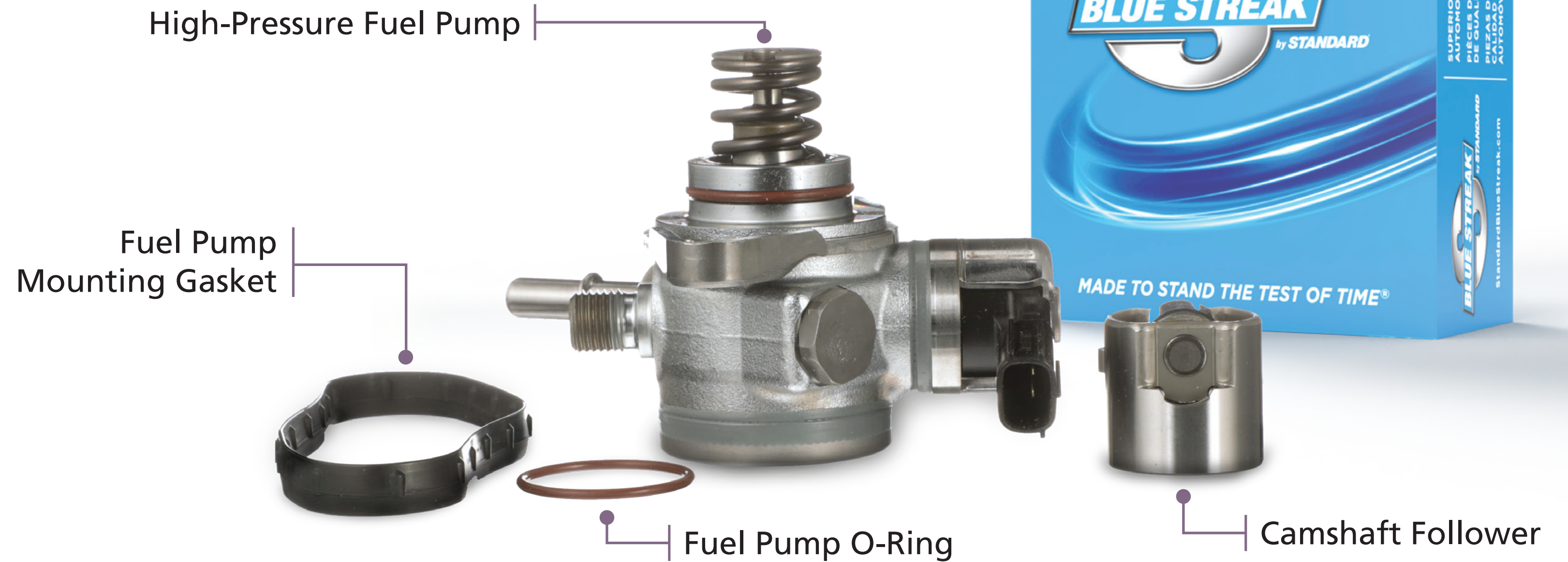

Ford Trucks, Vans & SUVs
(2019-11) VIO: 1.5M



What's New

INJECTORS

GDI is the fastest-growing fuel segment. Standard® is committed to introducing new GDI Injectors regularly to give you the parts you need.

For the most recent applications check the online catalog at StandardBrand.com.



FJ1547
Ford / Lincoln SUVs
(2022-20)
VIO: 220K



FJ1531
Hyundai / KIA Cars
(2020-19)
VIO: 97k



FJ1455
Toyota Cars & SUVs
(2020-18)
VIO: 1.7M



What's New

RELATED PARTS

Standard's GDI Program is much more than Injectors. We are continually adding to our industry-leading GDI components group including High-Pressure Fuel Pumps, Fuel Feed Lines, and other GDI replacement parts to make sure technicians have everything needed for a complete GDI service.

For the most recent applications, check the online catalog at StandardBrand.com.



High-Pressure Fuel Pump

GDP735

Honda / Acura Cars & SUVs
(2020-15)
VIO: 2M



High-Pressure Fuel Pump

GDP743

Subaru Cars & SUVs
(2022-19)
VIO: 1.5M



High-Pressure Fuel Pump

GDP748

Nissan Cars & SUVs
(2022-19)
VIO: 1M



Fuel Injector Seal Kit

SK202

Hyundai / KIA Cars & SUVs
(2022-91)
VIO: 4.8M



Fuel Feed Line

GDL715

Ford Cars & Trucks
(2021-18)
VIO: 1.4M



Fuel Pressure Sensor

FPS141

Ford / Lincoln Trucks & SUVs
(2021-19)
VIO: 2.1M



Top Movers: GDI Injectors

**IMPORT
APPLICATIONS**

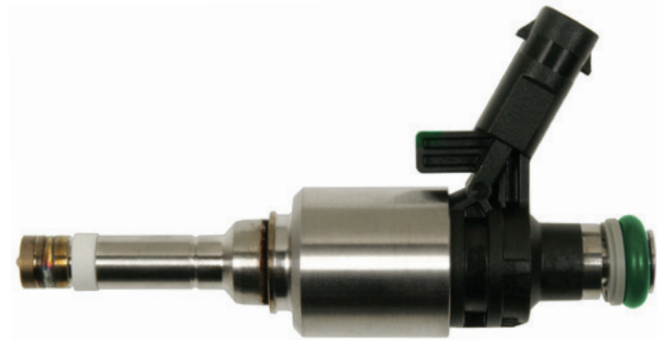

FJ1057

Audi / VW Cars & SUVs
(2017-08)

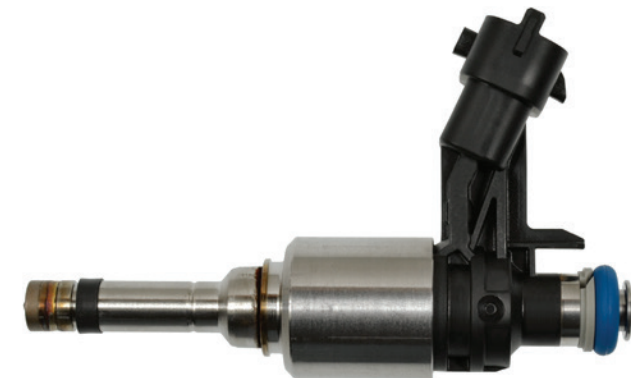

FJ1146

Hyundai / Kia Cars & SUVs
(2017-12)

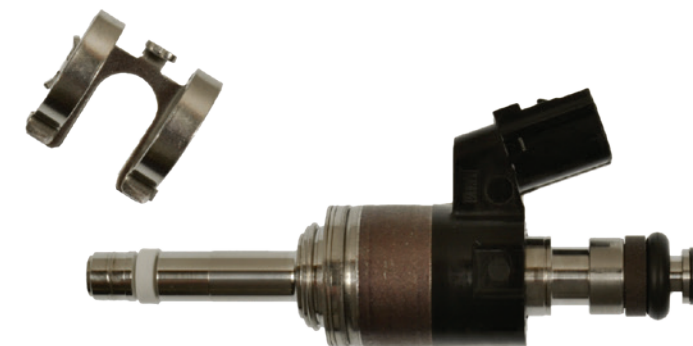

FJ1372

Honda SUVs, Trucks & Minivans
(2020-16)



FJ778

Mazda Cars & SUVs
(2013-06)

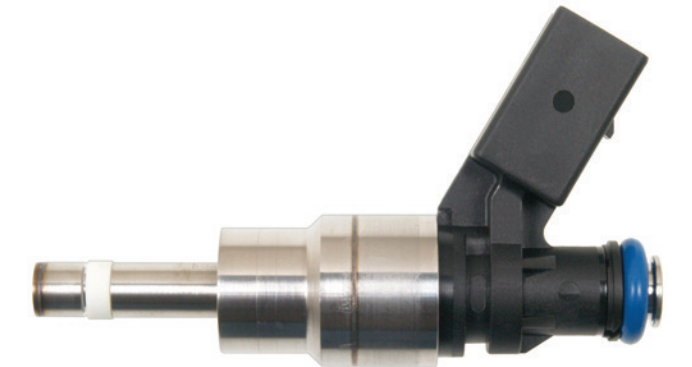

FJ856

Audi / VW Cars
(2011-05)

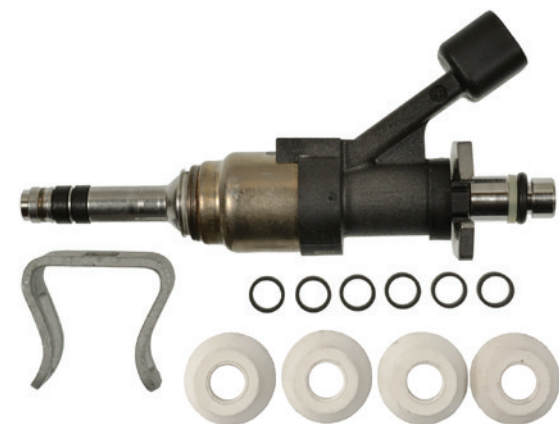

FJ1217

GM Trucks & SUVs
(2019-14)



FJ994

GM Cars & SUVs
(2011-08)

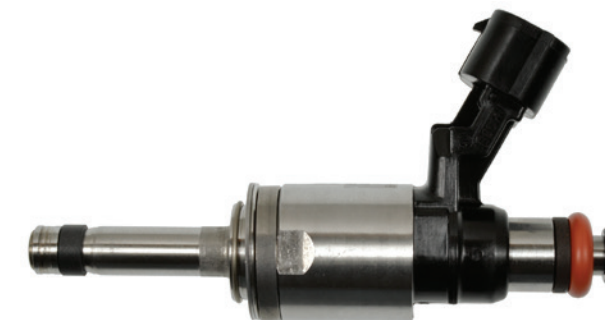

FJ1138

Ford / Lincoln Trucks & SUVs
(2019-11)

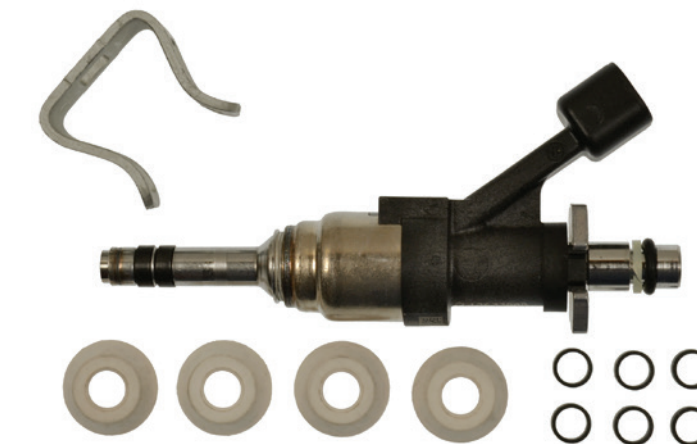

FJ1297

GM Cars, Trucks & SUVs
(2018-14)



FJ1157

GM Cars, Trucks & SUVs
(2022-12)



GDI Injection

StandardGDI.com

Related Components

The best GDI injector can't perform as designed with restricted fuel lines or worn gaskets.

Standard's GDI Program offers technicians everything they need for a complete GDI fuel system service.



GDI High-Pressure Fuel Pumps

GDI injectors operate up to 2,000 psi. Maintaining fuel pressure is critical to the optimal performance of GDI systems

100+ SKUs and coverage through 2022



GDI Fuel Feed Lines

Direct-fit OE replacement lines for high- & low-pressure applications

100+ SKUs with coverage through 2022



GDI Fuel Pressure Sensors

Monitors flow to deliver precise fuel injection performance

120+ part numbers for import and domestic applications



GDI O-Rings, Gaskets, and Plates

The right O-rings, gaskets and GDI plates are essential to a proper system service

Import and domestic coverage through 2022



GDI Injector Seal & Service Kits

When servicing GDI injectors, new O-rings and seals are required — never reuse O-rings and seals from an injector you are replacing

20+ SKUs covering import and domestic applications



GDI Camshaft Followers

Direct-fit OE replacement ensures proper fit, form, and function

Coverage through 2022



Standard[®] Quality

GDI requires a special injector that can inject fuel under the high-pressure requirements of cylinder compression.

Stainless steel calibration slide and spring assembly prevents corrosion within fuel control body leading to extended service life

High-temp Viton[®]
O-rings enable prolonged sealing of injector under extreme heat conditions

Precision wound and trimmed solenoid windings allow the computer to command efficient fuel delivery

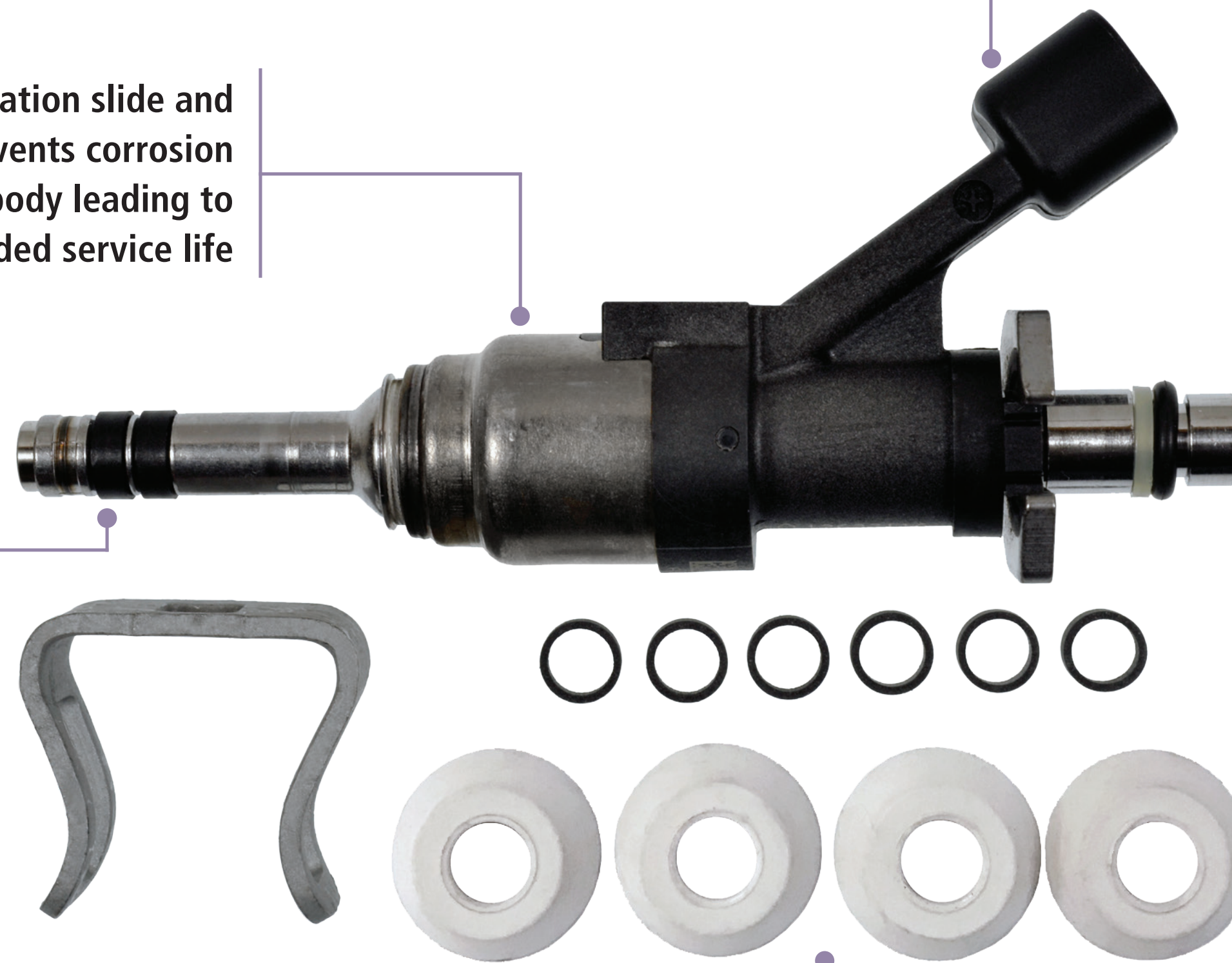

Included retaining clip keeps the injector in position while protecting against vibration

Additional O-rings and umbrella seals are included to ensure a trouble-free install



Standard[®] FJ1217
New GDI Fuel Injector
Chevrolet / GMC Trucks & SUVs
(2019-14)

Testing and Validation

Standard® subjects its Fuel Injectors to more than 35 different tests and inspections. To make sure every Fuel Injector meets our standards for precision quality, performance, and durability, Standard® performs initial life-cycle validation and 100% end-of-line testing.



Here are just a few of the elements and components that we test and inspect:

Body Color

Endurance

Spray Pattern

Body Style

Flow Linearity

Static Flow Rate

Coil Resistance

Flow Matching

Thermal Cycle Testing

Connector Shape

Humidity Storage

3 Axis Vibration

Dynamic Flow Rate

Shock Load

and more!



Standard[®] Solutions

Standard[®] GDI Injectors are always new,
never remanufactured.

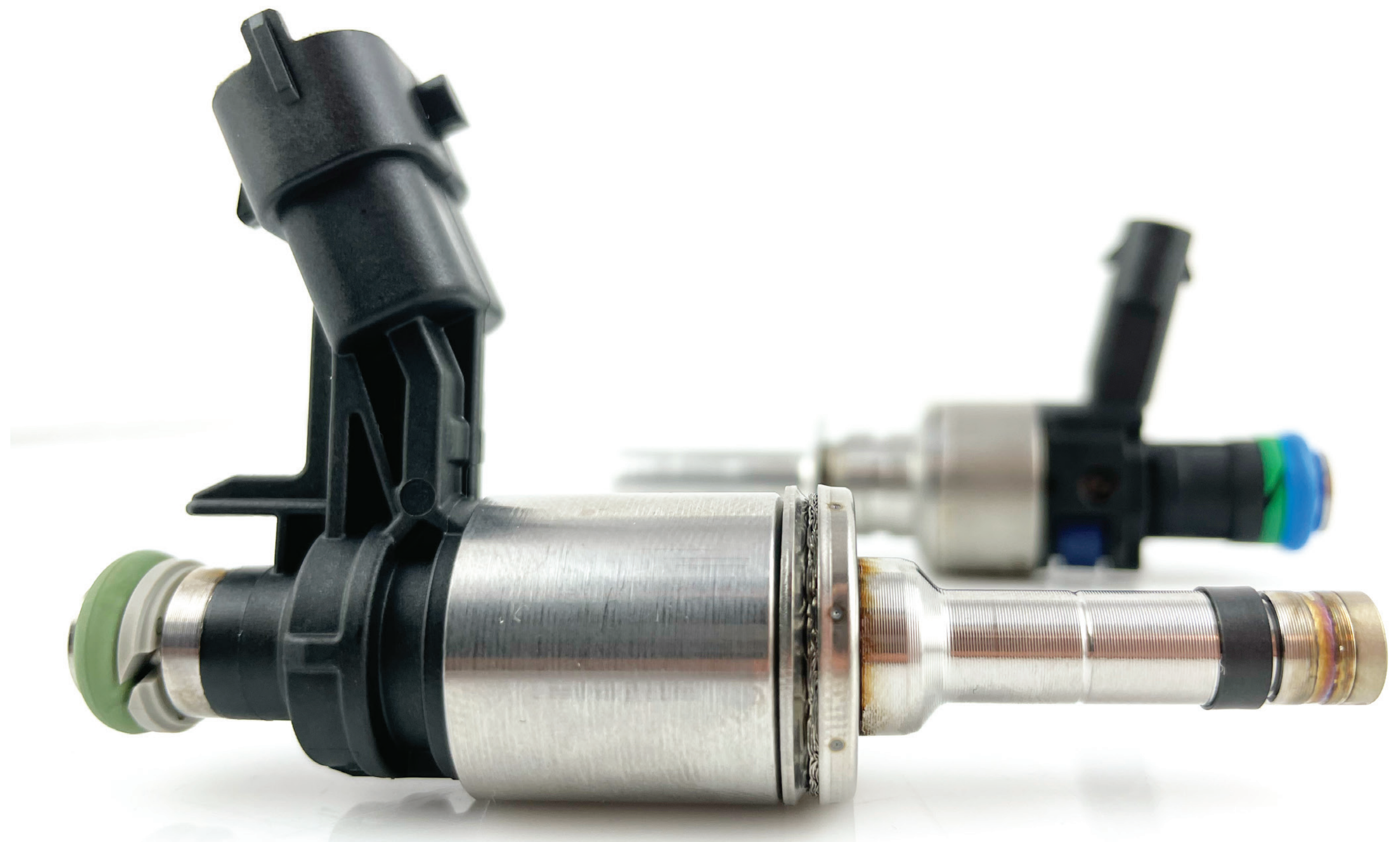

Most GDI injectors can't be remanufactured because they can't be disassembled to replace worn and failed components

Several aftermarket companies still offer GDI reman programs – and that's a problem. The injector isn't rebuilt, it's only cleaned, and internal components are more likely to fail sooner

Standard[®] only offers pristine, new GDI Injectors that deliver optimal performance and longevity



Standard[®] Pro Training Tech Tip

Standard[®] Pro Trainers have installed hundreds of GDI fuel injectors and trained thousands of technicians. Here's what they say to look out for during a GDI install.



When replacing or servicing GDI injectors, new O-rings and seals are required — you should never reuse O-rings and seals from an injector you are replacing



Any fuel line with a yellow tag is for one-time use only and must be replaced if it is removed



Standard® Professional Training

**Award-Winning In-Person, Live
Virtual, and Online Learning**

Standard® Pro Training delivers accredited classes that educate technicians in the latest automotive repair technologies, and techs can earn CEU credits.

An extension of Standard® training, our extensive YouTube video library has over 500 technical and installation videos.



Available Classes

Gasoline Direct Injection Tips

Diagnosing GDI

Fuel Trim Diagnostics

Diagnose Electronic Fuel Pump
Controls



Available Classes

GM Engine Controls

Toyota / Lexus Diagnostics

Ford EcoBoost

Misfire Diagnosis

Powertrain Electronics



For information on replacing GDI Injectors and components, search “GDI” on the **StandardBrand** YouTube channel

VSPG_2023_GDI_7-28

