



CAM/CRANK SENSORS

WHAT'S IN YOUR BOX?

We design and manufacture the highest quality camshaft and crankshaft position sensors.

Standard® and Intermotor® cam and crank sensors are designed and manufactured at our advanced Poland and North American IATF 16949-certified facilities.

As an expert design center for camshaft and crankshaft position sensors we start with the finest components, while maintaining a strict adherence to engineering excellence and precision manufacturing.

What's inside the Standard® box... advanced engineering, precision performance and over 100 years of experience. What's in your box?

It's this attention to detail that ensures every Standard® and Intermotor® cam and crank sensor meets or exceeds the original it's replacing for performance and durability.

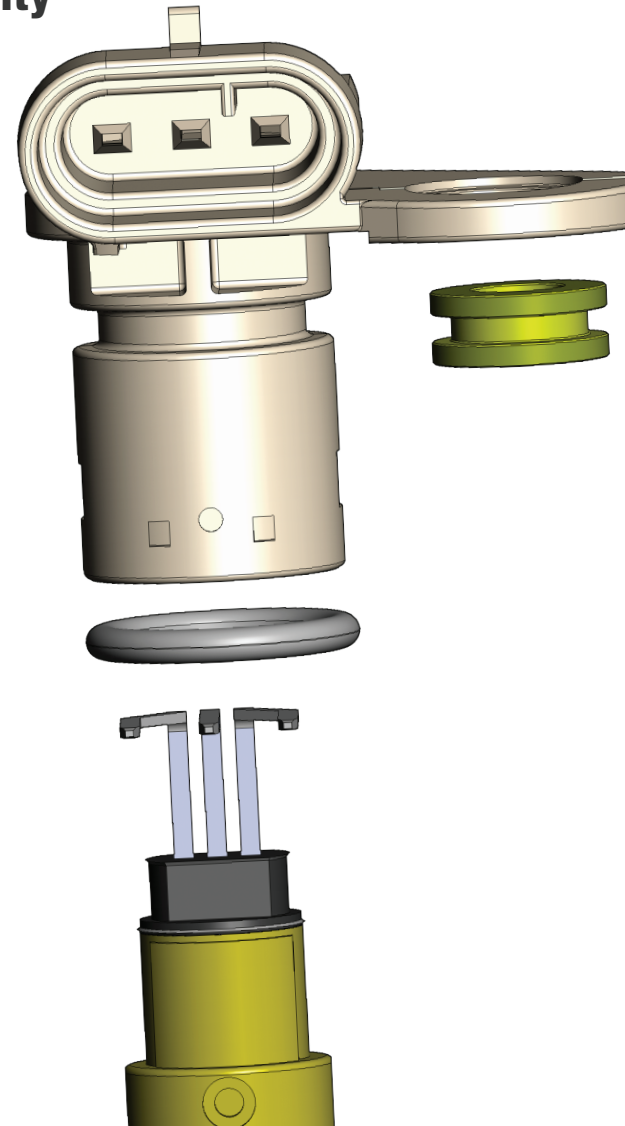

1000+
SKUs

More than 1000 SKUs and 95% coverage for domestic and import applications



All cam and crank sensors undergo extensive vibration and chamber testing to ensure durability



As an expert manufacturer, you know what to expect every time you open our box. Can your supplier say the same?

Our standards are so high, we know they'll meet yours.

We make sure every sensor that leaves our facilities meets our strict standards for quality, performance and durability.

OUR 48-HOUR VIBRATION TEST ENSURES DURABILITY

Sensors undergo three separate 48-64 hour vibration tests to ensure a long service life under the harshest conditions.

OUR CHAMBER TESTING ENSURES PERFORMANCE

Chamber testing cycles from -40°F to 257°F to ensure optimal operation in extreme temperatures.

WHAT OUR TESTING MEANS FOR YOU

Standard® and Intermotor® cam and crank sensors protect against short circuits and potential voltage issues to deliver precision performance and a long service life under all operating conditions.

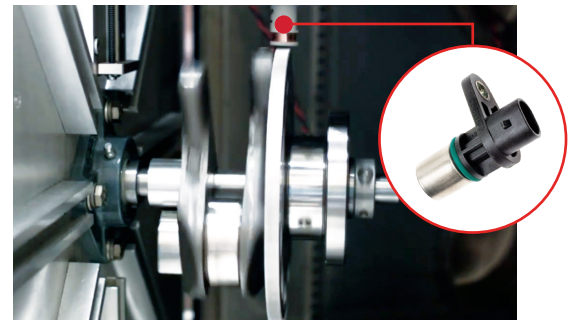
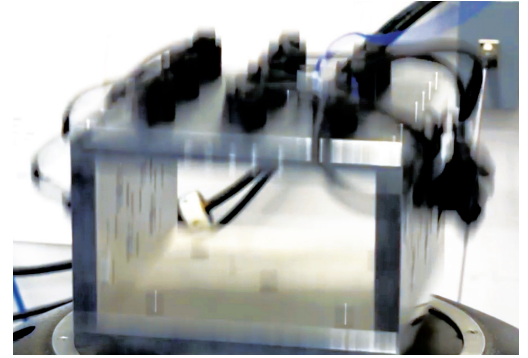

The anatomy of a superior crankshaft position sensor.

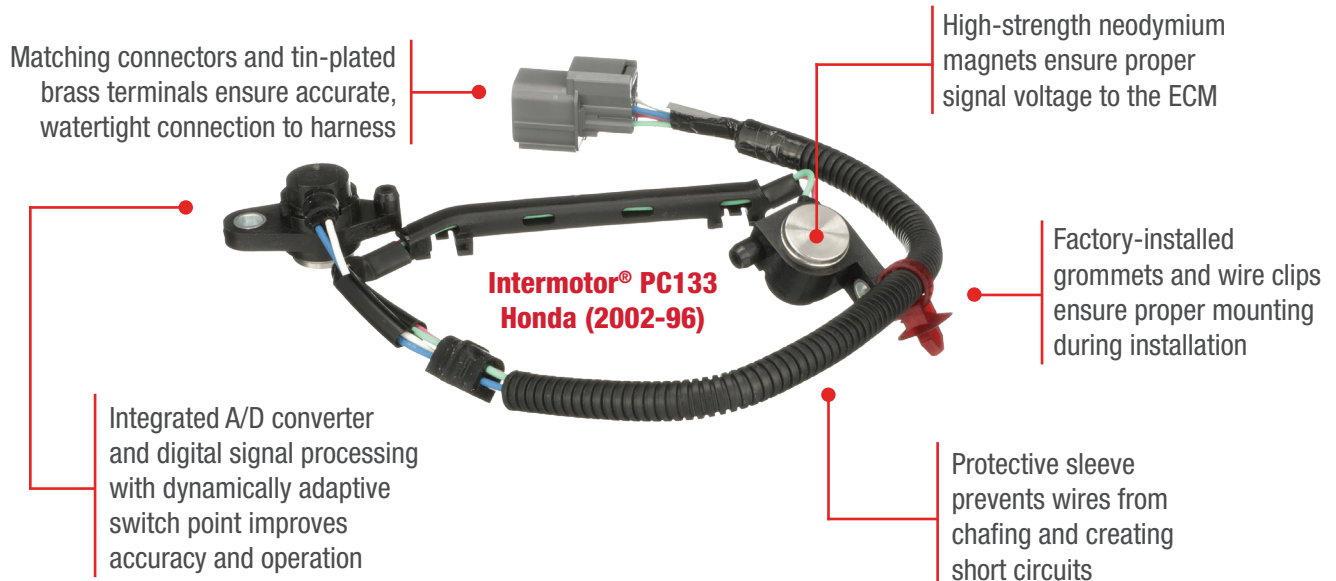

For more than 100 years, when the OE failed, technicians trusted Standard®, Blue Streak® and Intermotor® to deliver a part that's equal to or better than the original it's replacing.